

## NP435 & T18 4 SPEEDS 2WD TO BRONCO DANA 20 1966-77

### KIT CONSISTS OF:

No.	Qty	Part No.	Description
1.	1	51-1400	CASTING (Ref: 711114)
2.	1	716223	ALIGNMENT RETAINER
3.	1	716455	SNAP RING
4.	1	716512	GASKET
5.	1	716513	GASKET
6.	1	716713	SEAL (C/R #18676)
7.	1	716714	"O" RING SEAL
8.	2	723701	3/8-16 NUTS
9.	2	723704	3/8 LOCK WASHER
10.	2	723711	3/8-16 X 2" STUD
11.	2	725004	HEX NUT 1/2"-13 NAT
12.	4	725016	S.H.C.S. 1/2"- 13 x 1-1/2"
13.	2	725040	1/2"-13 x 2.00 STUD

#### NOTE:

The T18 and NP435 2WD output shafts may need the threaded portion of the shaft cut off to prevent bottoming out in the stock spud shaft.

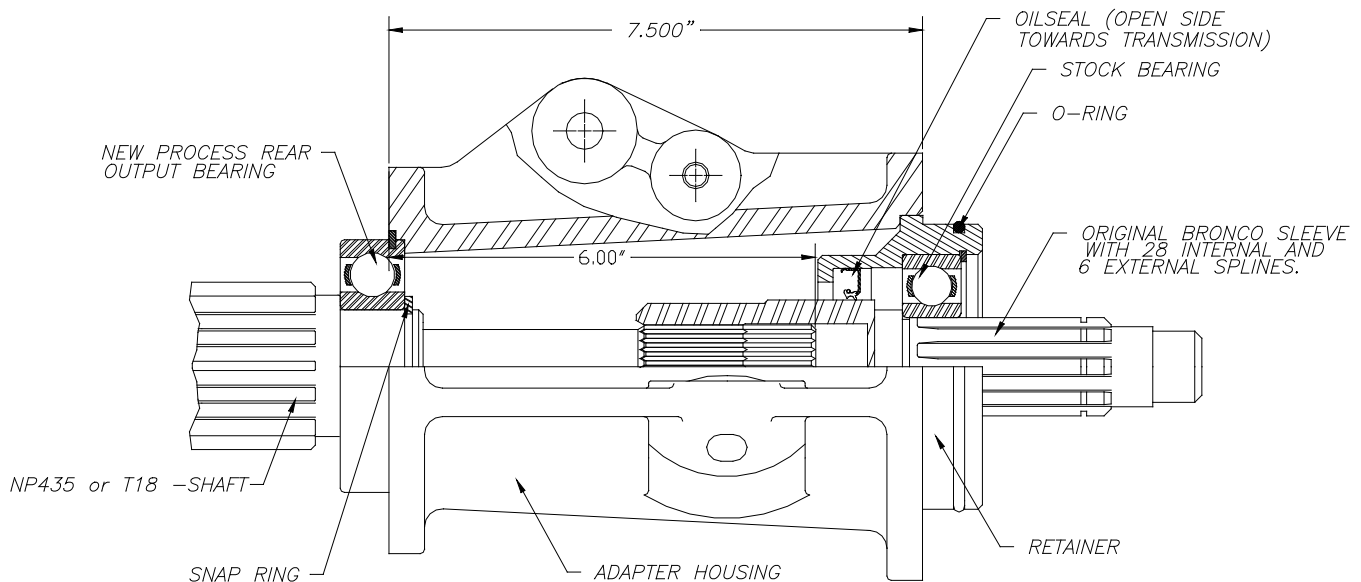

**SPECIAL NOTE:** The components packaged in this kit have been assembled and machined for specific type of conversions. Modifications to any of the components will void any possible warranty or return privileges. If you do not fully understand modifications or changes that will be required to complete your conversion, we strongly recommend that you contact our sales department for more information. This instruction sheet is only to be used for the assembly of Advance Adapter components. We recommend that a service manual pertaining to your vehicle be obtained for specific torque values, wiring diagrams and other related equipment. These manuals are normally available at automotive dealerships and parts stores.



P.O. Box 247, 4320 Aerotech Center Way  
Paso Robles, CA 93447  
Telephone: (800) 350-2223 Fax: (805) 238-4201  
PAGE 2 OF 2 Page Rev. Date: 05-14-19  
P/N: 50-2700

## NP435 & T18 4 SPEEDS 2WD TO BRONCO DANA 20 1966-77

### FORD NEW PROCESS NP435 & T18 4 SPEED:

The NP435 transmission can be identified by a case length of 10.875" and a case casting number of C95711, C96391, or C13894. The aluminum shift cover has a casting number of C11240, C97233 or C994569. The P.T.O. opening is on the right hand side at the center of the case and the shift cover is mounted to the top of the case with 8 bolts. The NP435 transmission required for this kit is from Ford F100, F200 & F300 1 ton trucks. The front bolt pattern on the Ford transmissions will have an 8-1/2" x 6-1/4" bellhousing pattern with a bellhousing pilot diameter of 4.848".

This kit is designed for a 2WD 28 spline output shaft with a 5-1/2" to 6.00" stickout. When using a NP435, driveline modifications can normally be eliminated. When using a T18, driveline modifications are normally required. The assembled length of the transmission and adapter will vary depending on which installation you are doing. If you select the proper transmission, you will be able to leave the existing main shaft inside the transmission and avoid any disassembly. When replacing the transmission shaft on a NP435 using Part No. C7TZ7061C, be sure that all transmission assembly work is done by a competent mechanic. All surfaces must use gaskets to prevent oil leakage.

When bolting the adapter to the main transmission case, you must use two studs in the lower two holes of the adapter. A slight modification may be necessary to obtain the proper clearance around the lower bearing cover of the stock NP435 transmission.

We have come across two different bolt patterns on the back side of the transmission case. The difference is between two wheel and four wheel drive applications.

**NP435:** If the transmission was originally used in a four wheel drive vehicle, then the lower two holes will be spread further apart approximately .050" each side. The upper two holes will need to be added to match the NP435 pattern. If the transmission was originally used in a two wheel drive vehicle, The pattern on the 51-1400 casting should be correct.

**T18:** 2WD or 4WD transmissions should line up with the pattern on the 51-1400 casting.

When installing the new transfer case adapter, make sure that the coupler and the output shaft do not bottom out. We have found on occasion that a transmission output shaft may be slightly longer than we have allowed. When coupling the factory spud shaft, we have found a small amount of interference. The adapter housing and spud shaft must be assembled to the back of the transmission without interference. **DO NOT FORCE THE NEW TAIL-HOUSING ONTO THE TRANSMISSION.** If assistance is needed, please feel free to call the number listed above.

The transfer case linkage will be able to bolt back in the original position on the new adapter housing. **The "J" style linkage may require some modification to retain this transfer case linkage.** A new seal has been supplied for the adapter housing and it must be installed with the open side towards the transmission. The "O"-ring provided should be installed on the hub that inserts into the transfer case opening.

On vehicles that are replacing the Dana 21 transfer case, you will need to change your crossmember and drill new holes in the crossmember portion of the new adapter housing. The conversion will also require a Spicer Yoke No. 2-42801X.

**SPECIAL NOTE: This kit is designed for the 2WD version of the NP435 & T18. If you obtained a 4WD NP435 transmission, new holes will need to be drilled on our casting to line up to your transmission bolt holes.**

**SPECIAL NOTE:** The components packaged in this kit have been assembled and machined for specific type of conversions. Modifications to any of the components will void any possible warranty or return privileges. If you do not fully understand modifications or changes that will be required to complete your conversion, we strongly recommend that you contact our sales department for more information. This instruction sheet is only to be used for the assembly of Advance Adapter components. We recommend that a service manual pertaining to your vehicle be obtained for specific torque values, wiring diagrams and other related equipment. These manuals are normally available at automotive dealerships and parts stores.