



ALUMINUM OFF-ROAD TRUCK AVENGER™ CARBURETOR

0-93670, 0-93770, 0-95670, & 0-95770

**INSTALLATION, TUNING, AND
ADJUSTMENT MANUAL**

199R10488

NOTE: These instructions must be read and fully understood before beginning installation. If this manual is not fully understood, installation should not be attempted. Failure to follow these instructions, including the pictures may result in subsequent system failure.

TABLE OF CONTENTS:

INTRODUCTION:.....3

REMOVAL:4

INSTALLATION NOTES:.....4

CHRYSLER APPLICATIONS4

FORD APPLICATIONS.....5

GM APPLICATIONS6

INSTALLATION:.....6

CHOKE ADJUSTMENT:.....9

ELECTRIC CHOKE.....9

MANUAL CHOKE9

IDLE MIXTURE NEEDLES:10

FLOAT LEVEL ADJUSTMENT:11

VACUUM OPERATED SECONDARY THROTTLES:.....12

VACUUM OPERATED SECONDARY TUNING:.....12

JETTING (MAIN JETS):.....13

CARBURETOR SPECIFICATIONS:13

HOLLEY® TRUCK AVENGER™ LIMITED LIFETIME WARRANTY14

INTRODUCTION:

CONGRATULATIONS on your purchase of the Off Road Truck Avenger™ Carburetor! We feel that you have purchased the finest off-road performance carburetor manufactured today. Should you need information or parts assistance, please contact our **Avenger Technical Service Department at 1-866-464-6553**. Please have the part number and sales receipt ready when calling.

The Off Road Truck Avenger™ Carburetor is a new evolution in off road carburetor technology. Holley has answered the call for a new carburetor that can handle the rigors of off-roading, while maintaining fuel control under demanding situations. Your new Truck Avenger™ Carburetor has the capability to control fuel slosh and booster bleed in the following situations:

- Climbs up to 40 degrees
- Side hill maneuvers up to 30 degrees
- Steep descents up to 30 degrees

Enjoy your new carburetor and feel free to attack that obstacle with confidence knowing that Holley® has it under “control”.

IMPORTANT: The OFF ROAD TRUCK AVENGER™ carburetor has been factory wet-flowed and calibrated. The “out of the box” settings should be very close for all adjustments.

To preserve warranty, these instructions must be read and followed thoroughly before and during installation.

NOTE: The Off Road Truck Avenger™ Carburetor kit has not yet been submitted for emissions testing and therefore, has not received an Executive Order Exemption from the California Resources Board. This means that your vehicle will NOT be “Smog Legal” in all 50 states with this kit installed.

These carburetors have been designed and calibrated as a universal carburetor for light truck applications. It is designed for use on “square” flange intake manifolds. It is not designed or recommended for towing applications. Carburetor adapters are not recommended to adapt to “spread” bore intake manifolds, since adapters may have an adverse affect on cylinder-to-cylinder distribution and ultimately, total engine performance. However, some manifolds may be universal (such as Weiland® 8004). Please check with Holley’s Avenger Technical Service Department if you have any questions.

REMOVAL:

1. Remove the air cleaner, exercising care to carefully detach any vacuum lines from the air cleaner and marking them so they can be reassembled to the air cleaner in the same manner.
2. Remove the existing carburetor by the following procedure:
 - A. Carefully disconnect the fuel line.

WARNING: Carefully protect the open end of the fuel lines, so that no foreign particles can enter. Wrap the end of the fuel line with a clean lint-free cloth.

- B. Disconnect and mark all vacuum lines and wiring (if any) to the carburetor.
 - C. Disconnect the PCV hose.
 - D. Disconnect the choke rod or heat tubes (if equipped).
 - E. Disconnect and remove the throttle linkage and automatic kickdown linkage. **SAVE ALL RETAINING CLIPS.**
 - F. Unbolt and remove the carburetor from the manifold.
3. If the intake manifold is being changed at this time, install the new manifold according to the manifold's manufacturer's directions. Since we are not familiar with all manifold instructions, Holley® cannot accept responsibility for their validity. We recommend that you only use Holley® / Weiand® manifolds, which you can find at your nearest dealer.

INSTALLATION NOTES:

CHRYSLER APPLICATIONS

WARNING: This carburetor is not designed for use with any Chrysler automatic overdrive transmission. SEVERE transmission damage may result from improper application use.

1. Unless you are replacing an existing Holley® carburetor (which already has a lever extension arm), you may need to purchase and install a throttle lever extension (Holley® P/N 20-7) on the carburetor. Remove the throttle stud and nut from the original carburetor. You can purchase a new stud from your Holley® dealer (Holley® P/N 20-67). Install the stud in the throttle lever extension (Figure 1). See the appropriate service manual for transmission adjustment.

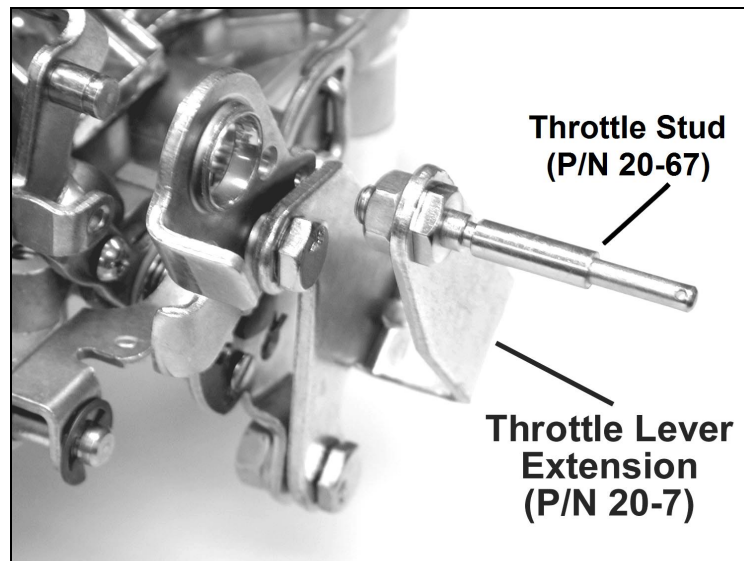

Figure 1—Chrysler applications

FORD APPLICATIONS

WARNING: This carburetor is not designed for use with any Ford automatic overdrive transmission. **SEVERE** transmission damage may result from improper application use.

NOTE: Unless replacing an existing Holley® Carburetor, you will need to purchase Holley® P/N 20-91, spring and perch kit, for Ford automatic transmissions.

1. Install the new throttle ball, lockwasher, and retaining nut to the carburetor throttle lever in the same position as the existing carburetor.
2. Insert the transmission kickdown screw with the black retaining clip on the transmission kickdown lever (Figure 2). This assembly must be installed according to the detailed drawing (Figure 3). See the appropriate service manual and page 8 of these instructions for proper transmission adjustment.

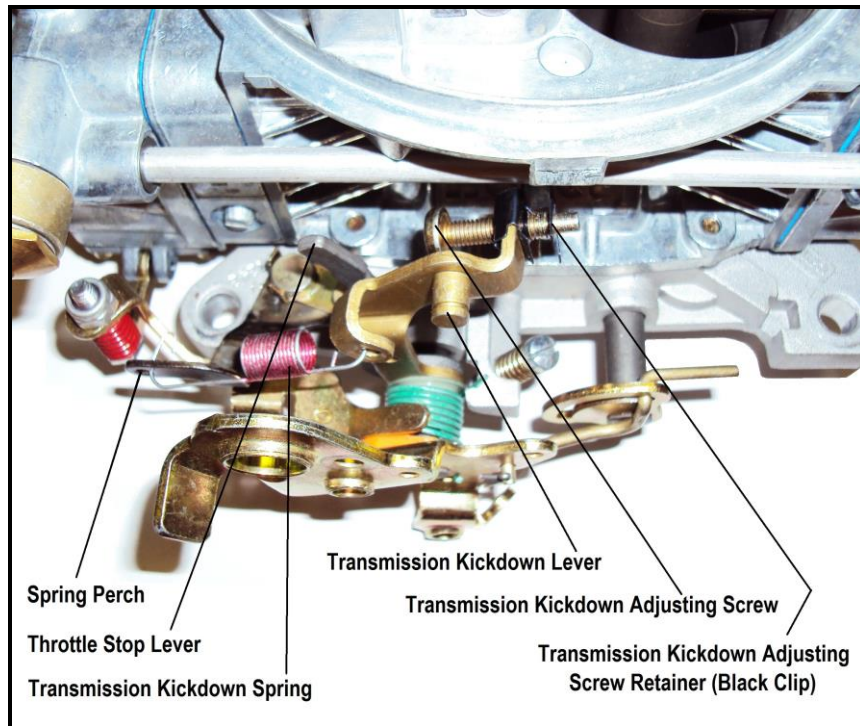

Figure 2—Ford applications

3. Remove the lock out screw from the kickdown lever (Figure 4).
4. Install the transmission kickdown spring between the transmission kickdown lever and spring perch (Figure 2).

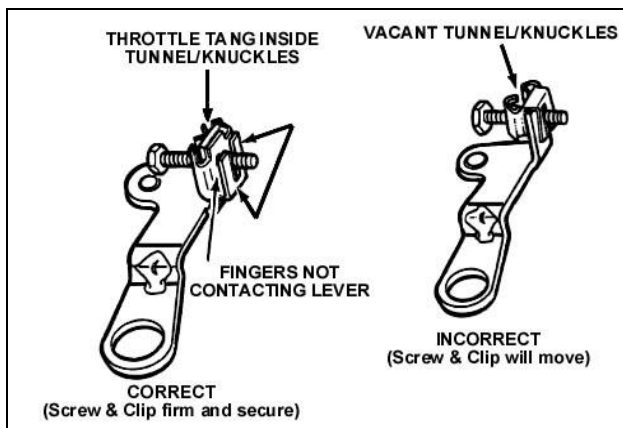

Figure 3—Ford applications

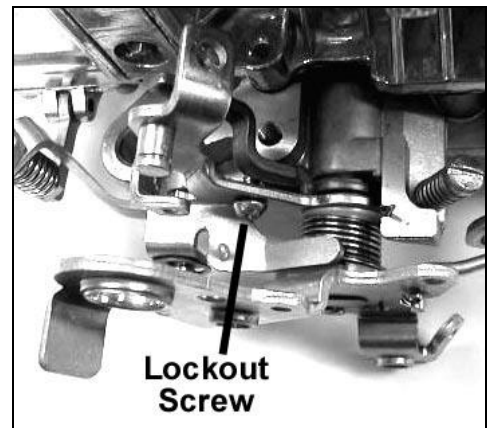

Figure 4—Ford applications

GM APPLICATIONS

WARNING: If you are using this carburetor with a GM overdrive transmission TH700R4 or a TH200R4, you must use a transmission kickdown cable bracket (Holley® P/N 20-95) and stud (Holley® P/N 20-40). Otherwise, **SEVERE** transmission damage **WILL** result. This carburetor is not designed to work with **ANY** other automatic overdrive transmission.

1. Remove the throttle cable ball and automatic transmission kickdown stud (if any) from the original carburetor, and mount these in similar locations on the Holley® throttle lever. If the original throttle cable is too large, a new throttle ball or stud is needed (Holley® P/N 20-2 or 20-38). See the appropriate service manual for transmission adjustment.

INSTALLATION:

1. Install the carburetor-mounting studs (not provided) in the proper location on the intake manifold carburetor flange.
2. Place the new carburetor flange gasket, provided with the carburetor, in the proper position on the intake manifold.
3. Place the carburetor on top of the flange gasket on the manifold. Install the hold-down nuts and snug down progressively in a “crisscross” pattern (60-80 in./lbs.), as shown in Figure 5.

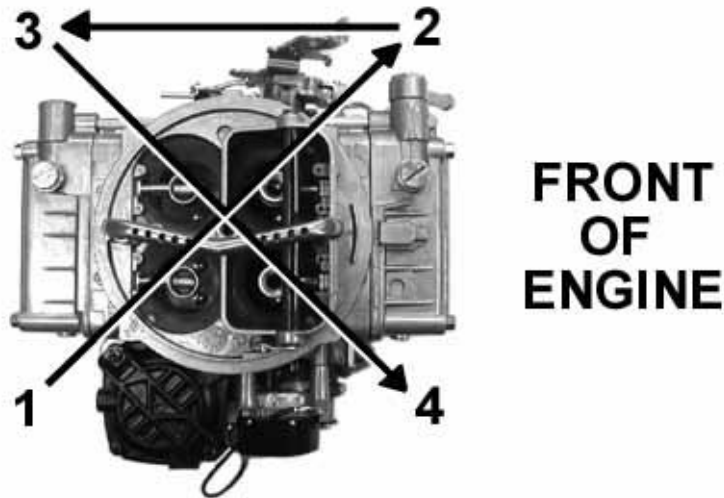

Figure 5

WARNING: Overtightening may result in a warped or cracked carburetor throttle body.

4. Before connecting the linkage, operate the throttle lever to ensure the correct travel (no sticking or binding), by opening to wide-open throttle and back to closed throttle several times. Correct any sticking or binding conditions before proceeding.

WARNING: Any sticking, binding, or other interference in the throttle linkage could result in uncontrolled engine speed. This could result in engine damage or personal injury.

5. Reconnect the throttle and transmission kickdown linkage and throttle return spring (Holley® P/N 20-89). Operate the carburetor throttle lever by hand to ensure the correct travel (no sticking or binding) by opening to wide-open throttle and back to closed throttle several times. Correct any sticking or binding conditions before proceeding.

NOTE: With the engine turned off, have an assistant slowly press the accelerator pedal to the floor, while you watch the throttle for any sticking or binding. Correct any sticking or binding conditions before proceeding. Also, ensure that you are reaching full throttle. Many performance problems are traced to partial throttle openings from improperly adjusted linkage. Secondaries will not open mechanically during this procedure.

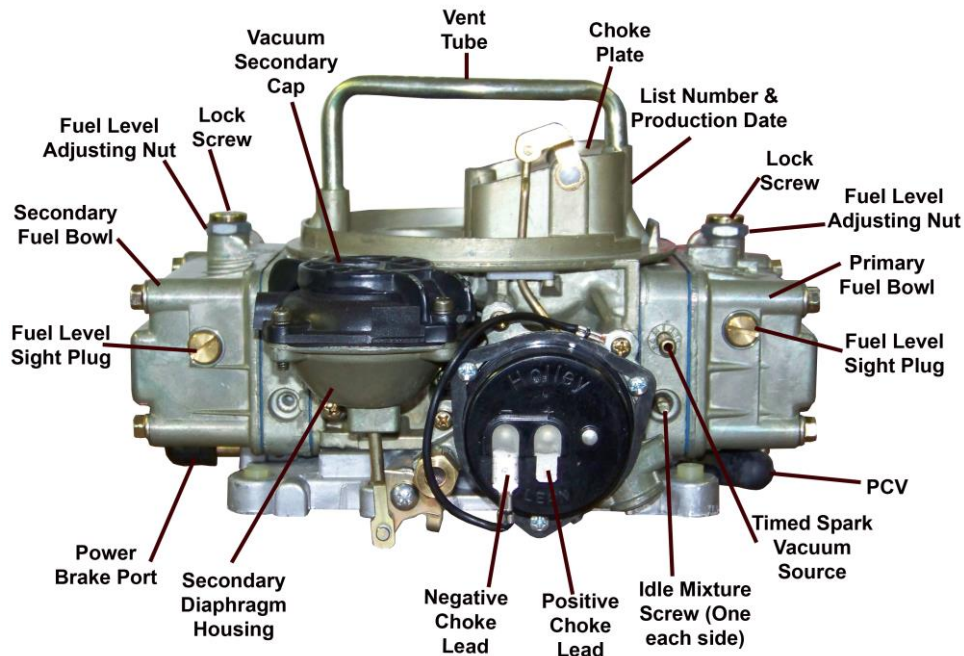

Figure 6

6. Reconnect the appropriate vacuum hoses to the carburetor, noting the correct fitting from Figure 6 and 7. Replace any cracked or dry rotted hoses at this time to prevent any vacuum leaks.
 - A. The full manifold vacuum source in the front of the throttle body provides vacuum for proper operation of the air cleaner, the pump diverter valve (if equipped), AC/Cruise, and/or the temperature sensing valve. If vacuum for more than one component is needed, use small plastic vacuum "T"s (available at most automotive stores).
 - B. The timed spark fitting in the choke side of the primary metering block provides vacuum for the operation of the distributor vacuum advance. Connect the hose to the distributor, spark delay valve, and/or temperature sensing valve as originally connected. Again use "T"s as necessary. If any questions arise about the hose connections, consult the proper service manual.
7. Connect the PCV hose to the PCV fitting in the carburetor.
8. Connect the power brake hose (if applicable) to the fitting as shown in Figures 6 or 7.

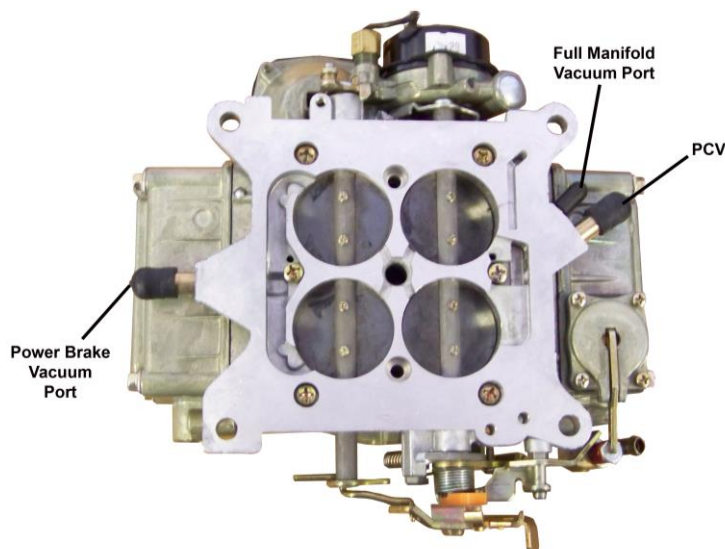

Figure 7

WARNING: During the fuel line installation, DO NOT allow any foreign particles to enter the fuel lines, which could then cause flooding and may result in a fire.

NOTE: If installation requires cutting the metal fuel line, cut the fuel line with a good tube cutter. This will minimize the chance of producing metal chip particles. If a hacksaw must be used then metal chips must be removed.

WARNING: In all cases where the fuel line has been cut, it is essential that it be clean to ensure that no metal particles enter the fuel bowl after the new carburetor installation. Remove the fuel line at the pump and blow the line clean with compressed air. **DO NOT** use the procedure where the coil wire is disconnected, the engine cranked for a few revolutions, and the fuel collected in a container. This procedure is unsafe because sparking can occur either at the coil or at the distributor end of the coil wire and ignite any fuel spilled in the engine compartment.

CAUTION: The use of a quality in-line fuel filter, such as Holley® P/N 162-523 is mandatory as a safeguard against possible flooding, which could result from unfiltered particles becoming lodged between the fuel inlet needle and its seat. This can result in fire if a spark is present or backfire occurs in the engine compartment. Air cleaner filter elements should be blown clean with compressed air at 6,000 miles and replaced at 12,000 miles to ensure maximum protection. Now would be the perfect time to upgrade to a Holley® Powershot air filter.

9. For choke hookup, attach the bayonet end of the long electrical lead supplied to the positive terminal on the choke cap. **The other end must be connected to an ignition-activated 12-volt source.** The distributor side of the ignition coil is **NOT** a 12-volt source. It is a 7-9-volt source after cranking.

WARNING: Connecting the choke cap to the ignition or ignition coil could result in unacceptable choke operation, poor fuel economy, and possible engine misfiring, since the voltage delivered to the spark plugs will be severely reduced by the drain imposed by the choke cap. Suitable ignition activated 12-volt sources are most electrical relays, as well as the leads to accessories, such as windshield wipers. **DO NOT** connect this wire to the original equipment (O.E.) electric choke source. This may not be a 12V source.

10. Check the voltage source with a volt-ohm meter to assure proper voltage and choke operation.

11. Start the engine and check the fuel line and inlet fitting for possible leaks.

NOTE: The recommended fuel pressure is 5-7 psi.

12. Recheck to assure all existing vacuum hoses are attached properly. Plug any fittings not used.

13. With the engine at operating temperature, set the idle speed to the manufacturer's specifications (see page 9 for idle adjustment).

14. Shut off the engine and readjust the throttle operated transmission linkage, if necessary. On installations that have a kickdown-actuating switch on the passenger's side of the firewall, it might be necessary to readjust it according to the manufacturer's service manual.

FORD APPLICATIONS WITH AUTOMATIC TRANSMISSIONS: With the engine off, push the transmission kickdown rod rearward until it stops and hold it in position. Push the throttle lever rearward to its wide-open throttle position and adjust the transmission kickdown screw to come in contact with the transmission kickdown lever tang.

WARNING: On Ford C-4 and C-6 automatic transmission vehicles only, install the transmission kickdown adjustment screw and black retaining clip, as correctly indicated. Failure to attend to this detail may result in a sticking wide-open throttle or dangerous uncontrolled engine speed.

WARNING: With the engine off, recheck the assembled linkage for sticking and/or proper return to the idle position.

15. Place the air cleaner gasket (supplied) on the sealing flange, and install the air cleaner.

16. With some air cleaner configurations, it may be necessary to use an air cleaner spacer to provide adequate clearance between the carburetor and the air cleaner. Holley® offers such a spacer (Holley® P/N 17-13). Depending on the overall height, obtain the proper length 1/4 x 20 stud and install in the carburetor airhorn. Close the hood slowly to ensure adequate clearance between the air cleaner stud and the hood.

WARNING: Inadequate clearance between the air cleaner and the throttle lever could result in throttle sticking and uncontrolled engine speed. Check the clearance between the throttle lever and air cleaner for proper operation. Check the clearance between the air cleaner and the hood before closing the hood completely.

MAINTENANCE WARNING: Fuel system components, including fuel lines and the carburetor, should be inspected periodically to assure no fuel leakage and to ensure the soundness of the hoses. Today's clean emissions engines provide higher temperatures in the engine compartment. These high temperatures promote faster aging of non-metallic materials.

Hoses that exhibit surface cracks, when bent to 180°, should be replaced. The presence of liquid fuel demands tightening of fittings, hose replacement, and retorquing of the fuel system component flange nuts. Periodically check the torque on the fuel bowl screws to 25-30 in./lbs. to assure proper fuel metering.

GENERAL: Some very important factors to optimize efficiency and performance include: Correct engine timing, correct spark plug gap and heat range, ignition components in good working order, and correct operation of exhaust heat valve.

CHOKE ADJUSTMENT:

ELECTRIC CHOKE

IMPORTANT: The TRUCK AVENGER™ carburetor has been factory wet-flowed and calibrated. The “out of the box” settings should be very close for all adjustments. The following tuning section is included **ONLY** to aid you in fine tuning adjustments.

1. You can control the choke operation by rotating the choke cap. If the choke comes off too soon, loosen the three screws and rotate the choke cap counterclockwise one notch at a time, until the choke operation is satisfactory. Rotate the choke cap clockwise, if the choke comes off too late. After making the final adjustments, start the engine and make sure the choke plate opens completely.
 - A. A choke that comes off too soon could exhibit one or more of the following symptoms: stalling, surging, backfiring, stumbles, or poor vehicle driveability when the vehicle is cold.
 - B. A choke that comes off too late could exhibit one or more of the following symptoms: black smoke from the tail pipe, poor driveability when cold, poor gas mileage, misses, or rough idle.
2. From the factory, the choke cap has built-in limiters. If choke operation is unsatisfactory and you have adjusted the choke cap in either direction to the limiters with unsatisfactory results, recheck your positive electrical line connection.
3. If the fast idle RPM is too low or too high for your preferences, **TURN THE ENGINE OFF**. Advance the throttle to wide-open, exposing the fast idle set screw below the choke housing (See Figure 8).
4. Using a 1/4” open end wrench, turn the screw clockwise to increase the RPM or counterclockwise to decrease the RPM. The factory setting should give you a 1500-1600 RPM fast idle speed.

NOTE: All vacuum ports must be plugged at this time.

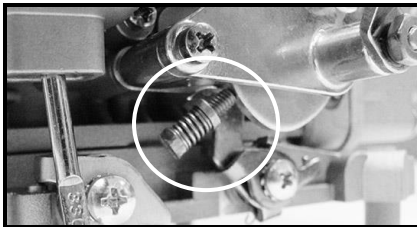
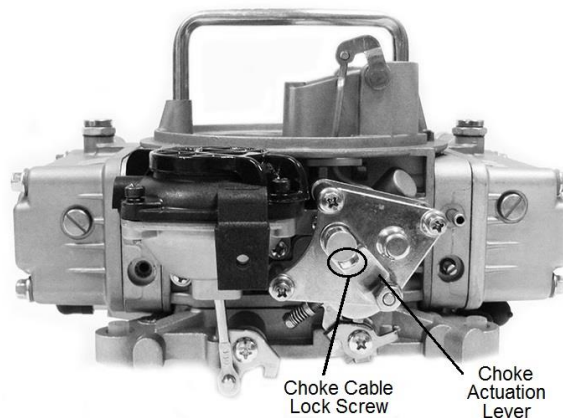

Figure 8 – Fast Idle Speed Screw

MANUAL CHOKE

1. Connect the choke control cable (Holley® P/N 45-228) to the choke actuation lever and lock in place with the choke cable lock screw.
2. Mount the outer sleeve to the cable clamp.
3. Actuate the choke cable through its full range of motion to ensure full choke operation. Adjust as necessary.



IDLE MIXTURE NEEDLES:

Idle mixture needles control the air/fuel mixture at idle. These have been preset at the factory and SHOULD NOT need any adjustments. However, if you feel that adjustment is necessary, you can use the following procedure to do so. When tuning the idle mixture, you're actually tuning for the best manifold vacuum. Idle mixture needles are found on the primary metering blocks. If you change one idle mixture needle, you must change the other idle mixture needle by the same amount. Here are the proper steps for setting the idle mixture needles.

1. Attach the vacuum gauge to a manifold vacuum port on the throttle body (Figure 7).
2. Adjust each idle mixture screw (Figures 9 & 10) 1/8 turn at a time, alternating between each screw. Turn them equally, until you achieve the highest possible vacuum reading or smoothest idle without adjusting the curb idle speed screw. Turn screws in to lean the mixture. Turn them out to richen the mixture.

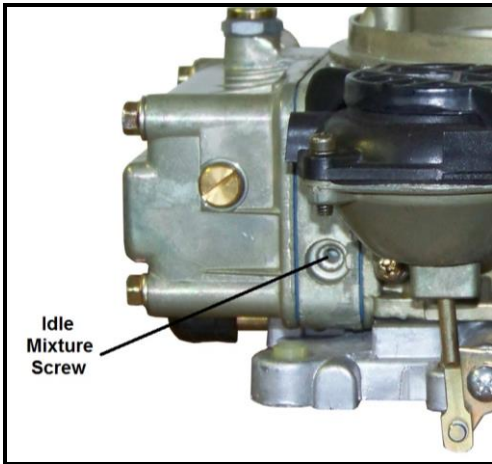

Figure 9

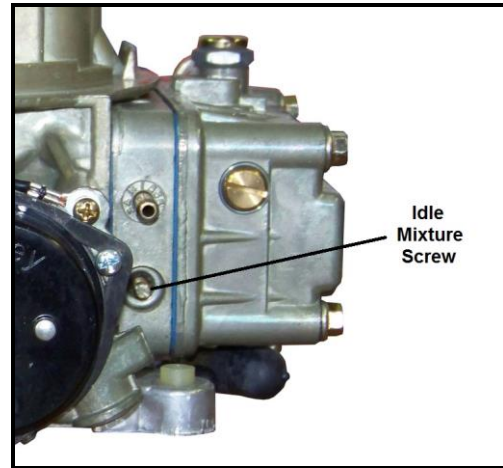

Figure 10

3. Now that the idle mixture is set, it may be necessary to go back and reset the idle speed using the curb idle speed screw, as shown in Figure 11.
4. If a vacuum gauge is not available, use a tachometer to obtain the highest RPM.

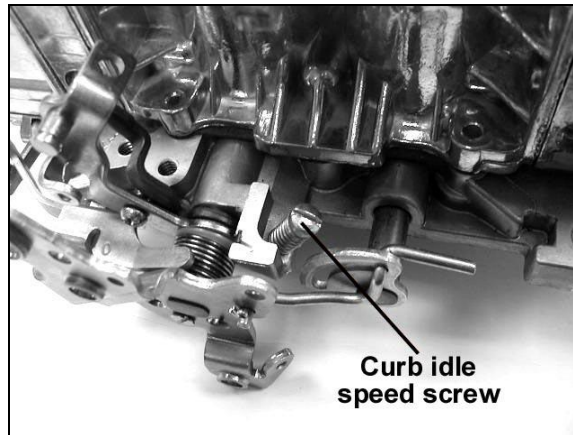

Figure 11

ROUGH IDLE AND VACUUM LEAKS: If a rough idle persists after the engine has been started and the mixture screws adjusted, check for manifold vacuum leaks. These could result from unplugged vacuum fittings or a carburetor flange gasket that was torn during installation. Recheck for proper attachment of all vacuum lines and check the lines for cracks. If the manifold was changed, a manifold vacuum leak could occur at the cylinder head/manifold surface due to damaged gaskets or improper torquing. Frequently, manifold vacuum leaks occur from the valley side of the manifold. These are very difficult to detect, unless a discernible whistle can be heard.

NOTE: In most cases, when rough idle occurs after a carburetor/manifold change, they result from manifold vacuum leaks similar to those described above. Assuring a proper manifold installation rather than assuming the carburetor is not functioning properly will ultimately save time.

FLOAT LEVEL ADJUSTMENT:

Primary and secondary float adjustments are set at the factory, but variations in fuel pressure could cause a change in these settings. To aid in adjustment of the float levels, clear sight plugs are included in the drop kit. You can install these to make the adjustments. After the adjustments are made you must re-install the brass sight plugs. The following procedure shows how to make these adjustments:

1. Remove the Brass sight plugs
2. Install the clear sight plugs per the instructions included with the plugs.
3. Start the vehicle.
4. Observe the sight plug for the fuel level. If none is seen, the level is too low. If it is higher than the bottom of the sight window, it is too high. **NOTE:** A properly set float level will have the fuel level located at the bottom edge of the sight window, as shown by the line in Figure 12.

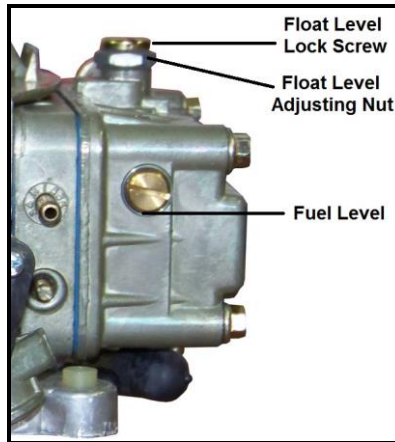

Figure 12

5. To adjust, shut down the engine.
6. Loosen the lock screw on top of the fuel bowl just enough to allow you to turn the adjusting nut. Hold the screw in position with the screwdriver.
7. Using a 5/8" wrench, turn the adjusting nut in the appropriate direction: Clockwise to lower float and counterclockwise to raise float. Turn the adjusting nut in increments of 1/4 of a rotation. Retighten the lock screw.
8. Restart the vehicle and observe the sight window.

NOTE: Rocking the truck slightly from side to side may make it easier to see the float level through the sight window.

9. Repeat steps 1 through 8 as necessary.
10. Re-install the brass sight plugs

WARNING! Removal of the spring loaded needle and seat assembly may cause some components to fall into the float bowl. Therefore, if the removal of the spring loaded needle and seat assembly is ever attempted, Holley® recommends removing the float bowl first.

SECONDARY FLOAT LEVELS:

Very little fuel is drawn out of the secondary fuel bowls during idle operation. This makes it a little tricky to set the proper float level with the sight plugs installed. Many customers attempt to adjust the rear float level down by turning the adjusting nut clockwise, only to see the fuel level rise through the sight plug. This is due to the float being pushed down into the fuel, therefore displacing the fuel to a higher level. You will find it easier to adjust the float levels, if you rev the engine slightly by opening the secondaries between adjustments. This can be easily done by pushing upward on the secondary diaphragm stem or by rolling the secondary throttle shaft linkage forward on the driver's side of the vehicle. This will use fuel from the secondary bowl at a much faster rate, allowing the float level to seek the adjustment point that you have set. Once the floats have been set with this procedure, drive the vehicle, making sure the secondaries open and recheck the float level.

VACUUM OPERATED SECONDARY THROTTLES:

Many people have the misconception that opening the secondary throttles sooner will provide increased performance. Others think they must “feel” a kick when the secondaries engage. Still others believe that they should disconnect the vacuum diaphragm and make the secondaries open mechanically.

Before going any further, let’s discuss these points in a reverse order. First, if we could make our vacuum-operated secondary carburetors perform better by opening the secondaries mechanically, it would be to our advantage to do so since all that vacuum actuating hardware is expensive and requires much time and money to calibrate. Mechanical secondary carburetors all utilize a secondary pump shot to prevent bogging when the secondaries are opened. Secondly, those who “feel” a kick when the secondaries engage are actually feeling a flat spot during initial acceleration, because the secondaries have already begun to open and have weakened the fuel delivery signal to the primary boosters. The engine is struggling to increase speed and what they actually feel are the secondary nozzles “crashing in” as the engine finally reaches the speed where it provides the proper fuel delivery signal to primary and secondary venturi. Third, opening the secondaries early causes the situation described above. The secondaries must not open until the engine requires the additional air. This allows torque to increase along the peak torque curve. Performance is compromised less by holding the secondaries closed a little longer than by opening them a little too soon. If the opening rate of the vacuum operated secondaries is properly calibrated there should not be a “kick”, only a smooth increase in power should be felt.

VACUUM OPERATED SECONDARY TUNING:

The secondaries will not open by free-revving the engine. The engine needs to be under a load before they will open. If you are still uncertain if they are opening, you can take a normal paperclip and clip it onto the secondary diaphragm rod and slide it up against the bottom of the secondary diaphragm housing. Go out and drive the vehicle, making sure to get into the secondaries. When you return you will be able to look at the position of the paperclip on the rod. If it is lower on the rod, you can tell the secondaries opened and how far they opened. This is useful in determining if you need a heavier or lighter secondary spring.

1. Remove the air cleaner assembly.
2. Remove the 2 Phillips screws from the black vacuum diaphragm spring cap (Figure 15).
3. Lift off the cap and spring. Remove the spring from the cap. Replace with a softer (silver) spring, if desired.
4. The silver spring will allow the secondaries to open sooner (for light trucks) and increase performance.
5. The black spring (installed at the factory) will force the secondaries to open later (for heavier trucks) and increase fuel economy.



Figure 13

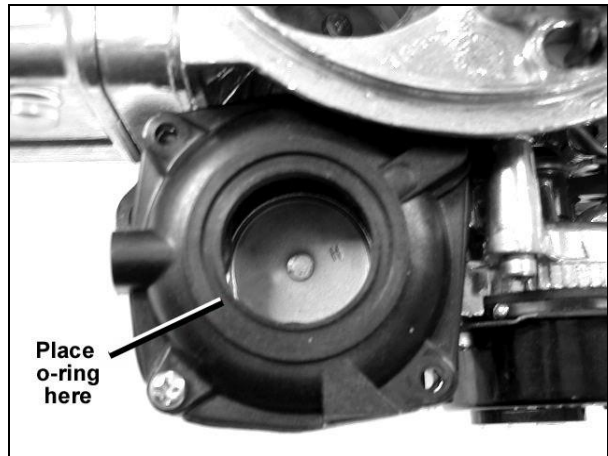

Figure 14

6. The black spring that comes in the Truck Avenger Carburetor kit has been calibrated to give the best performance and fuel economy in most applications.
7. Once you have selected a spring, attach it to the cap (Figure 13) by placing the small end of the spring over the center post on the cap. Check the o-ring seal and place the cap and spring back into the vacuum diaphragm housing (Figure 14).

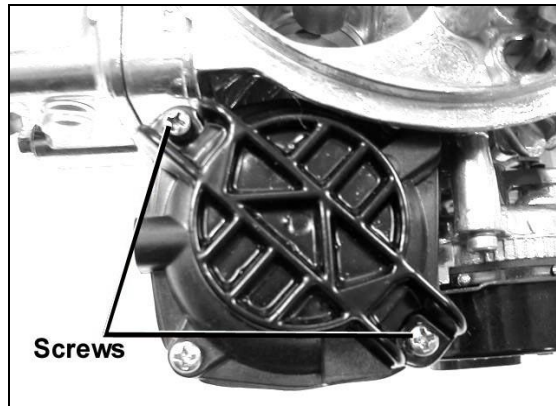

Figure 15

8. Tighten the two Phillips screws securely and reinstall the air cleaner, as shown in Figure 15.
9. Test drive the vehicle.

JETTING (MAIN JETS):

Due to varied applications that a universal performance carburetor will work with, a few tips on jetting are provided to help you understand their purpose.

1. Out of the box jetting is extremely close for most applications.
2. Carburetors are calibrated at sea level. Decrease the jet size primary and secondary, one number for every 2000 ft. increase in altitude.
3. Holley® jets are broached, flowed, and stamped according to flow rate. **NEVER** drill jets, as this seriously alters flow characteristics. Stamped numbers are reference numbers and **DO NOT** indicate drill size.
4. In most cases, it will be **unnecessary** to increase jet size more than four numbers greater than out of the box jetting. Exceptions could arise when the carburetor is mounted on a very large volume, plenum-ram manifold.
5. Spark plugs provide the best indication of proper jetting. Consult an ignition manual for proper reading of spark plugs.

CARBURETOR SPECIFICATIONS:

CARBURETOR #	PRIMARY METERING JET	SECONDARY METERING JET	PUMP DISCHARGE NOZZLE	PRIMARY POWER VALVE	SECONDARY POWER VALVE	SECONDARY DIAPHRAGM SPRING
R-93670/0-95670	68	89	0.028	25	N/A	Black
R-93770/0-95770	74	99	0.035	25	N/A	Black



HOLLEY® TRUCK AVENGER™ LIMITED LIFETIME WARRANTY

Holley® Performance Products warrants its Holley® Truck Avenger™ Carburetor to be free from defects in material and workmanship for the life of the product on parts and one year on repair labor. After a period of one year, Holley® will charge standard rates for repair labor. For any Holley® Truck Avenger™ Carburetor used in any type racing or off-road use will only be covered by a one (1) year limited warranty on parts and labor. Warranty performance will be initiated by returning the alleged defective product to HOLLEY® PERFORMANCE PRODUCTS with the original, dated purchase receipt. Purchaser is to call toll free, the Holley® Factory Service number at 1-866-464-6553 to receive details and shipping instructions.

Holley® Performance Products does not warrant products which have been (a) modified or altered outside factory specifications, (b) subjected to conditions such as abuse, misuse, neglect, accident, improper installation or adjustment, contaminants, water or corrosion, gum or varnish, use of improper or poor quality fuel or fuel additives, fire from a backfire, and faulty repair or (c) in other than those automotive applications recommended in a current Holley® catalog. Holley® shall not be responsible for (a) actual or alleged installation or removal labor, inbound shipment costs or other incidental charges or (b) actual or alleged incidental or consequential damages incurred by the use of a Holley® Truck Avenger™ Carburetor. Further, there are no warranties, which extend beyond those stated here.

This warranty is extended to the original consumer purchaser and has as duration the lifetime from date of original purchase by such consumer. **THIS WARRANTY IS EXPRESSLY IN LIEU OF ALL OTHER WARRANTIES EXPRESS OR IMPLIED INCLUDING, BUT NOT LIMITED TO, THE WARRANTIES OF MERCHANTABILITY AND FITNESS FOR A PARTICULAR PURPOSE AND ALL OTHER OBLIGATIONS OR LIABILITIES ON OUR PART. WE NEITHER ASSUME, NOR AUTHORIZE ANY OTHER PERSON TO ASSUME FOR US, ANY OTHER LIABILITY IN CONNECTION WITH THE SALE OF THIS TRUCK AVENGER CARBURETOR. WE MAKE NO WARRANTY WHATSOEVER IN RESPECT TO ACCESSORIES OR PARTS NOT SUPPLIED BY US. AS USED IN THIS WARRANTY, "PURCHASER" SHALL BE DEEMED TO MEAN ONLY THAT PERSON FOR WHOM THE TRUCK AVENGER™ CARBURETOR WAS ORIGINALLY PURCHASED.**

Final warranty determination will be the decision of Holley® Performance Products.

Some states do not allow the exclusion or limitation of incidental or consequential damages, or limitations on how long an implied warranty lasts, so the above limitations or exclusions may not apply to you.

This warranty gives you specific legal rights, and you may also have other rights that vary from state to state. This warranty shall apply only within the boundaries of the continental United States.

**Holley® Performance Products, Inc.
1801 Russellville Road
Bowling Green, KY 42101-3542**

Technical Service: 1-866-464-6553

© 2008 Holley Performance Products, Inc. All rights reserved.

199R10488

Revision Date: 4-2-15