

ADVANCE ADAPTERS INC.

P.O. Box 247, 4320 Aerotech Center Way
Paso Robles, CA 93447

Telephone: (800) 350-2223 Fax: (805) 238-4201

P/N: 50-2706

New Item: (10/96)

PAGE 1 OF 2

Page Rev. Date: 05-06-11

700R TO BRONCO DANA 20 TRANSFER CASE

KIT CONSISTS OF:

No.	Qty	Part No.	Description
1.	1	51-0209	CASTING - NV4500 TO BRONCO DANA 20
2.	1	51-6800	THIN CASTING - TH350 TO JEEP NEW PROCESS
3.	1	52-0209	SPUD SHAFT - NV4500/BRONCO DANA 20
4.	1	52-9101	SHAFT - 700R4 TO 23 SPLINE
5.	1	715523-SP	SPACER FOR SHIFTER BRKT TO CASTING
6.	1	715541	SHIFTER LINKAGE BRACKET
7.	1	716082	700R NYLON BUSHING
8.	1	716223	BEARING RETAINER
9.	1	716312	BEARING
10.	1	716455	SNAP RING
11.	1	716511	"O" RING
12.	1	716513	T/C GASKET
13.	1	716517	GASKET - NP208 T/C
14.	1	716713	SEAL
15.	1	716714	O-RING FOR INDEX RETAINER
16.	4	720046	10mm-1.5 THREAD x 40mm S.H.C.S.
17.	6	723701	NUT 3/8" - 16 PLATED
18.	6	723704	LOCK WASHER 3/8" PLATED
19.	6	723711	STUD BOLT 3/8" - 16 x 2" LG
20.	6	723740	H.H.C.S. 3/8" - 16 x 1-1/2"

NOTE:

This adapter will only work with the "T" style shifter. If your vehicle has a "J" style, it will need to be replaced

Optional items:

Part# 712588

(GM Trans x Ford Small Block)

SPECIAL INSTRUCTIONS:

This adapter kit is designed for exclusive use with a GM 700R transmission. The overall length of this transmission with the adapter is 25-7/8". Since this application is for a Ford Early Bronco Model 20 transfer case, you will need to consider how to couple the 700R to the Ford engine. We offer [P/N 712588](#) which will allow you to obtain this conversion. The overall length of your assembly with P/N 712588 will now be 26.25".

This kit is supplied with a new spud shaft, bearing, and seal. These components will need to be installed into our alignment retainer, along with the stock Bronco Dana drive gear. Make sure all snap rings are in place. Install the O-ring on the retainer along with a small amount of R.T.V. Blue silicone, then install the retainer to your transfer case. Bolt the adapter ring to the Dana 20 using

THE 700R HAD A DESIGN CHANGE ON THE OUTPUT SHAFT. THE OIL HOLE HAS BEEN RELOCATED TO THE CHAMFER ON THE SHAFT. THE INPUT HOUSING LUBE SEAL (SOFT AND RED IN COLOR) FOR THE LATER DESIGN SHAFTS MUST BE CHANGED TO THE HARD PLASTIC SEAL PROVIDED IN THE KIT. MOST OF THE OUTPUT SHAFTS WE USE ARE AN EARLIER DESIGN SHAFT WHICH WILL ONLY WORK WITH THE HARD PLASTIC WASHER SUPPLIED IN THIS KIT.

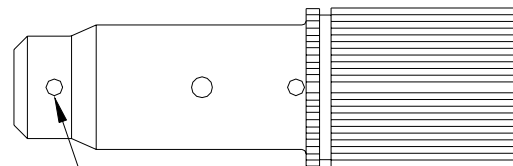

THE 700R PREVIOUS DESIGN LUBE HOLE LOCATION
EARLY DESIGN SHAFT (REQUIRES HARD PLASTIC WASHER)

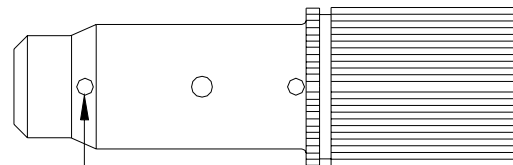

THE 700R REVISED LUBE HOLE LOCATION
LATE MODEL SHAFT (CAN USE EITHER SOFT OR HARD PLASTIC WASHER)

SPECIAL NOTE: The components packaged in this kit have been assembled and machined for specific type of conversions. Modifications to any of the components will void any possible warranty or return privileges. If you do not fully understand modifications or changes that will be required to complete your conversion, we strongly recommend that you contact our sales department for more information. This instruction sheet is only to be used for the assembly of Advance Adapter components. We recommend that a service manual pertaining to your vehicle be obtained for specific torque values, wiring diagrams and other related equipment. These manuals are normally available at automotive dealerships and parts stores.

ADVANCE ADAPTERS INC.

P.O. Box 247, 4320 Aerotech Center Way

Paso Robles, CA 93447

Telephone: (800) 350-2223 Fax: (805) 238-4201

P/N: 50-2706

New Item: (10/96)

PAGE 2 OF 2

Page Rev. Date: 11-15-02

700R TO BRONCO DANA 20 TRANSFER CASE

the (6) S.H.C.S. bolts. Rotate the spud shaft to check for proper installation.

When assembling the transmission to the transfer case, **DO NOT FORCE** the two gear boxes together. If the shaft is too long, there is the possibility of pre-loading the transmission bearings, causing premature failure. Take the extra time to make sure that the shafts do not bottom out internally. If there is any interference problem, it may be necessary to grind the end of the new output shaft to obtain the proper length.

A shifter bracket has been provided for a "T" style T/C shifter handle. Before installing your transmission/transfer case assembly in your vehicle, check the fit of this linkage bracket. The mounting hardware for the transfer case linkage has been left out due to the various "T" style linkages being used.

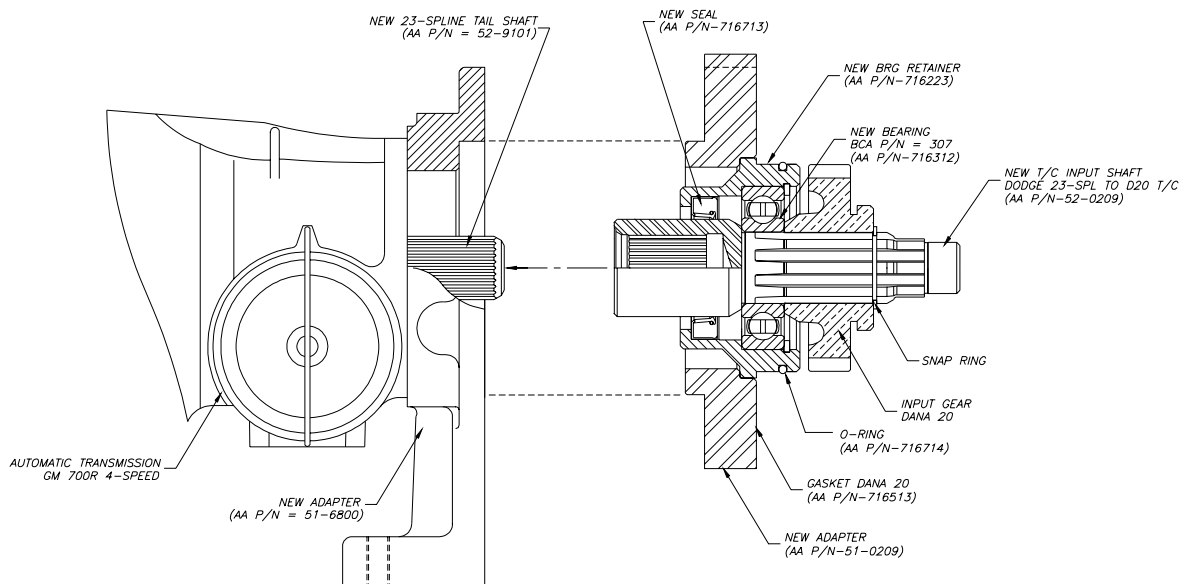

715541 shifter bracket

SPECIAL NOTE: The components packaged in this kit have been assembled and machined for specific type of conversions. Modifications to any of the components will void any possible warranty or return privileges. If you do not fully understand modifications or changes that will be required to complete your conversion, we strongly recommend that you contact our sales department for more information. This instruction sheet is only to be used for the assembly of Advance Adapter components. We recommend that a service manual pertaining to your vehicle be obtained for specific torque values, wiring diagrams and other related equipment. These manuals are normally available at automotive dealerships and parts stores.